

santiago chile IBTTA Technology Workshop November 12-14, 2006

IBTTA International Bridge, Tunnel and Turnpike Association

PBS&I

ORT: Conversion Rather than Green-Field

Presented By
 Massoud Moradi PE, AICP,
 Vice President
 National Toll Program Director

Tuesday, November 14, 2006

santiago chile IBTTA Technology Workshop November 12-14, 2006

PBS&I

Outline

- Why
- When
- How
- What
- What else
- What now

santiago chile IBTTA Technology Workshop November 12-14, 2006

PBS&I

Why Convert to ORT?

“Mr. Gorbachev, Tear Down This Plaza!”



santiago chile IBTTA Technology Workshop November 12-14, 2006

PBS&I

Why Convert to ORT?

- To improve traffic congestion relief and/or bring toll equity...

santiago chile IBTTA Technology Workshop November 12-14, 2006

PBS&I

Why Convert to ORT?

- High capital construction costs and unacceptable congestion
 - Inadequate Right of Way to add conventional lanes,
 - Inadequate space between interchanges for an express-lane plaza,
 - Frequency of interchanges requires too many tolling points to consider conventional plazas.



santiago chile IBTTA Technology Workshop November 12-14, 2006

PBS&I

Why Convert to ORT?

- To improve safety of motoring public and toll collectors by eliminating stopping at plazas,
- To improve air quality by eliminating queuing of stop and go vehicles,



santiago chile IBTTA Technology Workshop November 12-14, 200

When Convert to ORT?

- When operations costs for video tolling and violation enforcement can be passed on to video customers and violators.
 - Motivate customers to use transponders
 - Capture incremental video processing costs:
 - Image processing (US25¢ or more each),
 - Lookup costs depending on government agreements and data quality / need for supplemental services,
 - If these are captured, video tolling doesn't cost more than electronic toll collection tolling... or does it?

santiago chile IBTTA Technology Workshop November 12-14, 200

When convert to ORT?

- When considering costs, must also consider leakage:
 - Intentional violators
 - Rejected credit cards
 - Missing or illegible license plates
 - Interoperable toll accounts
 - Unusable images
 - System errors and "other" circumstances



santiago chile IBTTA Technology Workshop November 12-14, 200

When convert to ORT?

- When toll collection operating costs for ORT decrease to the existing level of operating costs with cash plazas.

With Cash Plazas

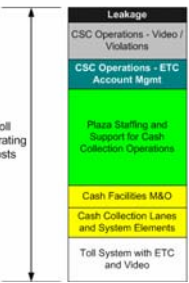

Without Cash Plazas



santiago chile IBTTA Technology Workshop November 12-14, 200

How Convert to ORT?

- Engineering decisions and details
 - Maintain original throughput
 - Safety of work zone
 - Net affect of greater throughput on downstream interchanges / roadways

santiago chile IBTTA Technology Workshop November 12-14, 200

What?



- In the beginning...

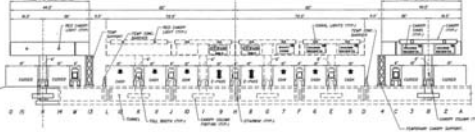

santiago chile IBTTA Technology Workshop November 12-14, 200

What?



Phase 1 pm traffic:				
	Southbound		Northbound	
	Oct 2002 Volumes	Capacity	Oct 2002 Volumes	Capacity
	1,480	1,500	2,490	3,000
	240	0	260	550
	730	900	860	900

santiago chile IBTTA Technology Workshop November 12-14, 200

What? **PBS**

- Phase 1 construction:



santiago chile IBTTA Technology Workshop November 12-14, 200

What? **PBS**

- Phase 2 construction:



santiago chile IBTTA Technology Workshop November 12-14, 200

What? **PBS**

- Phase 3a construction:



santiago chile IBTTA Technology Workshop November 12-14, 200

What? **PBS**

- Phase 3b construction:



santiago chile IBTTA Technology Workshop November 12-14, 200

What? **PBS**

- Phase 3c construction:



santiago chile IBTTA Technology Workshop November 12-14, 200

What? **PBS**

- Completion!



santiago chile IBTTA Technology Workshop November 12-14, 200

What else? 

- **May be time to replace system along with civil / traffic improvements:**
 - Systems age more quickly than physical facilities
 - Network standards and data storage requirements are much larger
 - Multi-lane ORT lanes may warrant a different technology approach than “a high-speed dedicated lane.”

santiago chile IBTTA Technology Workshop November 12-14, 200

What else? 

- **Need to locate vehicle across a wide area in multi-lane free-flow. Consider each ORT lane a single toll lane:**
 - One lane control, AVC & video set per lane,
 - places greater reliance on read-zone accuracy
 - OR
 - Treat entire roadway toll zone as one lane:
 - One lane control, AVC & video set per toll zone, w/
 - Lateral vehicle detection by signal / video triangulation.

santiago chile IBTTA Technology Workshop November 12-14, 200

What else? 

- **Need for video for audit of ORT lanes / toll zones:**
 - Ability to easily check classification issues
 - Were the tag-indicated and detected classifications correct?
 - Did the system correctly override a tag classification?
 - Ability to check transaction disposition
 - Did the correct transactions trigger the correct video image capture?
 - Ability to see the source of errant data such as ghost vehicles, if any.

santiago chile IBTTA Technology Workshop November 12-14, 200

What now? Abandoned Cash Facilities 

- Valuable real estate, already with data and power and often off-expressway access,
- **May support operations functions such as:**
 - Roadway maintenance vehicle storage,
 - Material, sign and traffic control device storage,
 - Accident recovery sites or other police support.
- **Older plaza lanes could conceivably be used for tag sales, or**
- **Demolish the old plaza lanes and use the site for a mini-mart service plaza.**

santiago chile IBTTA Technology Workshop November 12-14, 200



Thank You